

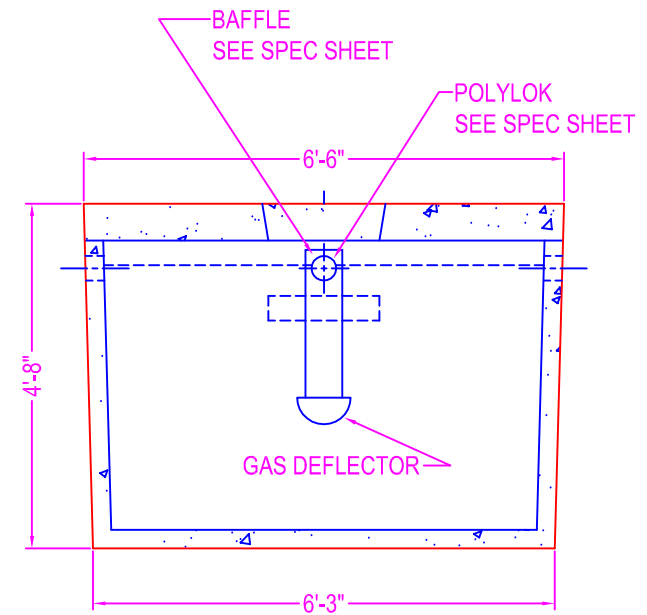
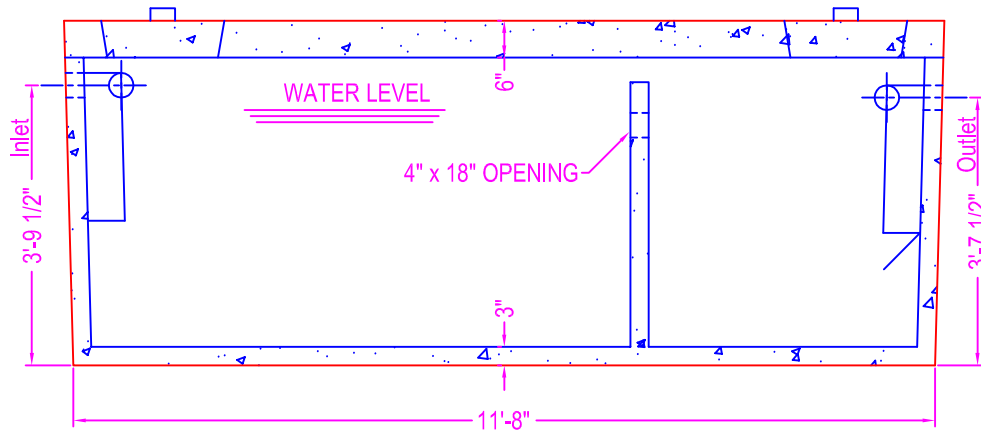
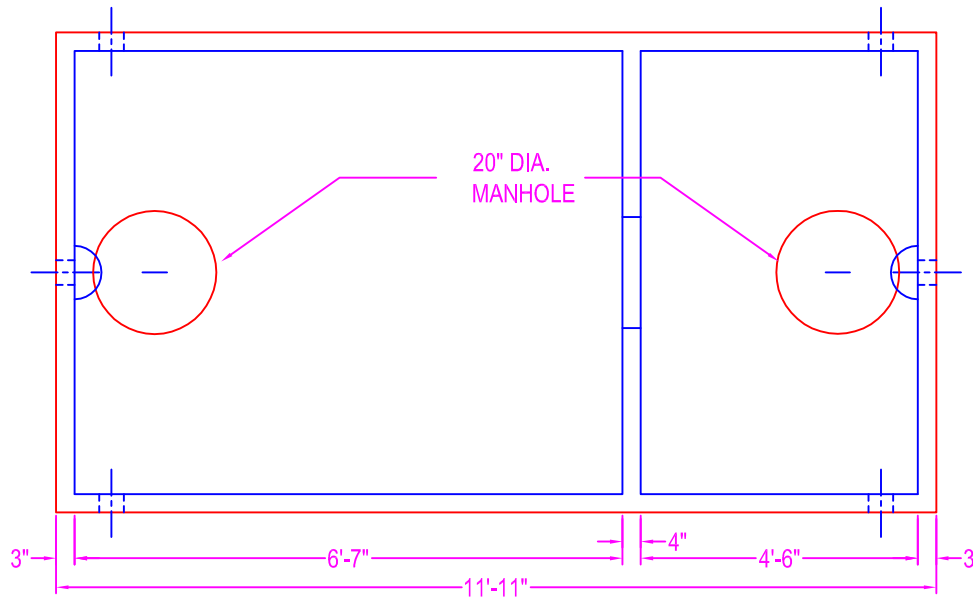

SEPTIC TANK ST-1500

3-INLETS
3-OUTLETS

NOTES:

- CONCRETE: 5000 psi @ 28 days
- REF: Matrix HPS fiber mesh
rebar grade 60 ASTM A615
- ENTRAINED AIR: +/- 5% to 8%
- DESIGN LOAD: 300 psf / non-traffic
- LIVE LOAD: N/A
- EARTH FILL: 24" max fill depth
- BUOYANCY FACTOR: N/A
- PIPE CONNECTS: polylok (cast in)
- BAFFLE: plastic baffle w/ gas deflector
on outlet opening
plastic baffle on inlet



 <p>Zeiser Wilbert VAULT, INC. CONCRETE PRODUCTS</p>	<p>750 Howard Street Elmira, NY 14904 Fax: (607) 737-0291 Phone: (607) 733-0568 1-800-472-4335</p>	<p>Title: ST - 1500 2 Comp</p>	<p>Drawn By: JPS</p>
	<p>Scale: Not To Scale</p>	<p>Drawing No.: 10131500</p>	
	<p>Date: 10-13-15</p>		