

REDUCING MANHOLE 6'-0" to 4'-0" DIA.

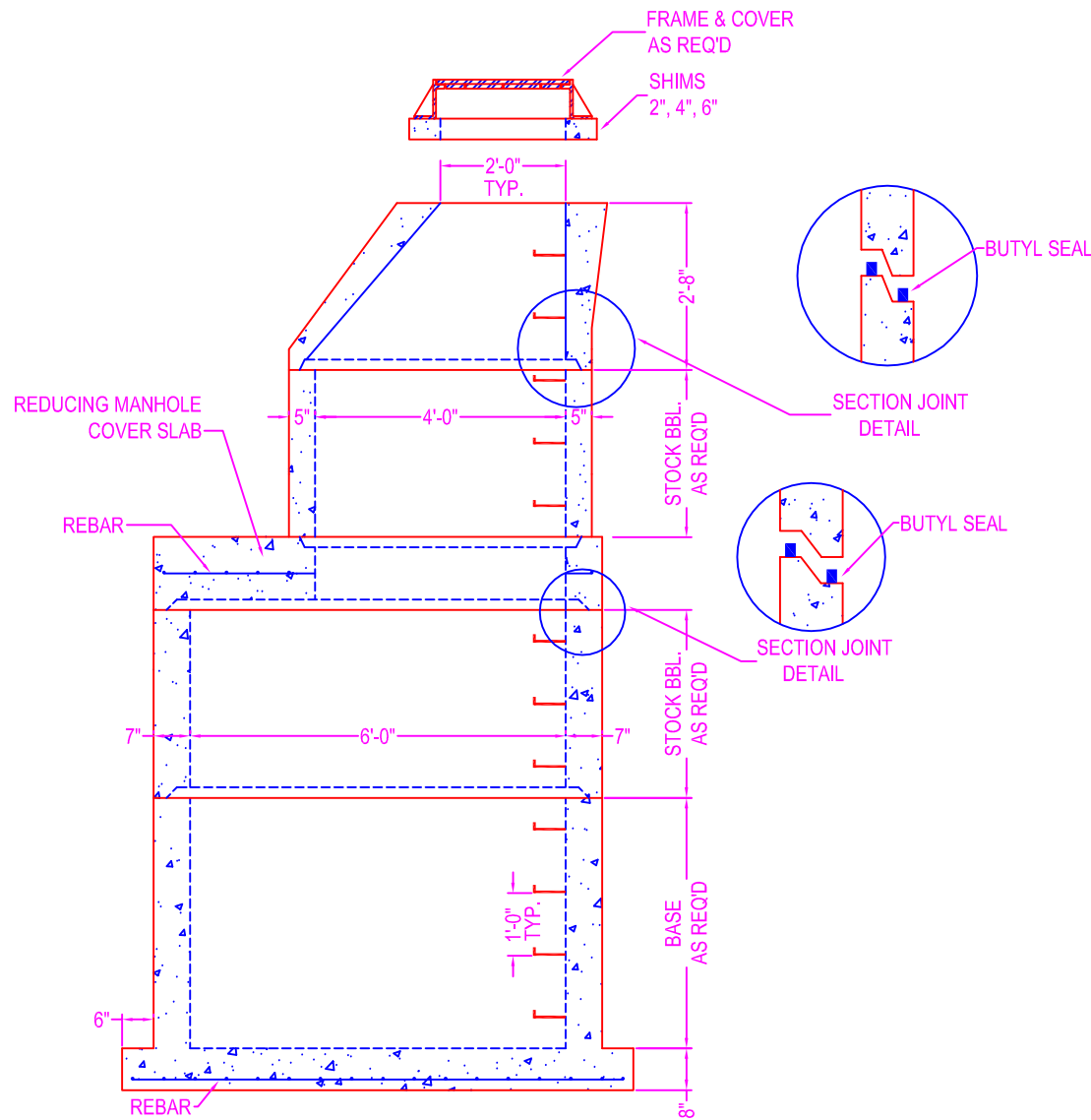

NOTES:

CONCRETE: 5000 psi @ 28 days

DESIGN SPECS: conform to latest ASTM C-478

STEPS: steel reinforced copolymer polypropylene plastic step conforms to latest ASTM C-478

OPENINGS: size & location to conform to dwgs.

TYPES:

- Coreout - pipe o.d. plus 4"
- Kor-N-Seal - details on spec. sheet
- Star Seal - details on spec. sheet

COATING: if req'd

TYPES:

- CS-55
- Epoxy
- In
- Out
- None

BUTYL SEALANT: @ each joint; see spec. sheet

Zeiser

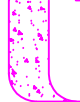

Wilbert
VAULT, INC.

CONCRETE PRODUCTS

750 Howard Street Elmira, NY 14904

Fax: (607) 737-0291

Phone: (607) 733-0568

1-800-472-4335

Title: Reducing Manhole

Scale: Not To Scale

Drawn By: JPS

Drawing No.: 03140600

Date: 3-14-06